

DA-G2 A2B FORD

— INSTALLATION AND USER GUIDE —

BRIDGING MEDIA, COMMUNICATION & LIFESTYLE WITH YOUR VEHICLE

mObridge

mObridge



CONTENTS

DISCLAIMER	4
WELCOME	5
OVERVIEW	6
Vehicle Compatibility	6
Kit Contents	6
DA-G2.Entry A2B Ford Kit	6
DA-G2.Standard A2B Ford & DA-G2.Pro A2B Ford Kits	6
Technical Specifications	8
HARDWARE INSTALLATION	9
System Layout	9
DA-G2.Entry A2B Ford	9
DA-G2.Standard A2B Ford & DA-G2.Pro A2B Ford	10
Installation Guide	11
Wiring Harness	11
Remote Wakeup	11
DIP Switches	12
Ford Factory Pinout	12
Speaker Harness	12
Power Harness	14
LED Status	14
GRAPHICAL INTERFACE OPERATION	15
Software Update	15
Speaker Mapping	18
Saving Setups & Presets	19
FCC INFORMATION & DISCLAIMERS	22

DISCLAIMER

mObridge makes every effort to try and keep the support and installation documentation up to date.

We do not reimburse or bear costs arising from installations should installation issues occur. mObridge can be contacted via email and also via its worldwide distribution network. We always recommend contacting the local distributor first, and although we endeavour to answer emails we receive in a timely manner, due to time zone differences we may not be able to respond immediately.

mObridge always recommends professional installation of these products as they are technically complex, involving CAN and A²B[®] wiring harnesses across multiple vehicle configurations and software versions within these vehicles.

In some cases, vehicles may require coding by specialist workshops and diagnostic equipment. mObridge always recommends allocating a number of hours to any installation, just in case any issues should arise.

PLEASE NOTE



This manual was accurate the day of printing however as mObridge products are software updatable, this manual may no longer contain the most current information. Scan the QR code for a link to our website where the latest version can be downloaded



WELCOME

Congratulations on your purchase of a mObridge DA-G2 A2B Preamp. mObridge prides itself on striving to develop and manufacture products to the highest engineering quality standards and seamlessly integrating these products with factory audiovisual systems.

The mObridge DA-G2 A2B series are some of the most advanced DSP aftermarket audio integration interfaces available for A² B[®] based vehicles and come with an easy to use Windows and macOS Graphical Interface for setting up and tuning the DA-G2 systems. This can be downloaded from www.mobridge.us.

This kit integrates with the OEM A² B[®] and CAN network to retain the original functionality of the OEM system including volume control, balance and fade, bass, mid-range and treble control, chime level control & Bluetooth voice calls. Depending on the DA-G2 A2B model, this kit adds many additional features to your audio system including TOSLINK output, channel mapping to 10 RCA output channels, 1024 point parametric graphic equalizer for each channel, as well as a 'master EQ', crossover type and crossover points for each speaker, crossover slope, individual speaker time alignment, phase adjustment, Q factor (both left and right), summing for subwoofers and centre channel upmixing. The user can also use the radio controls to change preset settings in the DA-G2 for different tuning profiles.

As with all mObridge products, we have included a USB for software updates, allowing for new features to be added as they become available. The DA-G2 A2B series can be updated by simply loading the latest software from our website and through the use of the mObridge DSP user interface.

The DA-G2 A2B series may also have system function upgrades available for purchase and download from time to time. These will also be available on our website.

We hope you enjoy your new enhanced listening experience!

OVERVIEW

VEHICLE COMPATIBILITY

The mObridge DA-G2 A2B Ford series is compatible with Ford vehicles that use the Sync 3 Infotainment system with a B&O or Revel amplifier. This includes most Ford models from 2018 onwards, including the Escape, Expedition, Explorer, F-150, F-250, F-350, F-450, F-550, Raptor, Everest, Endura, EcoSport, Focus, Puma and Fiesta. Please refer to the mObridge website to see the complete compatibility list for your product, www.mobridge.us/support

KIT CONTENTS

DA-G2.Entry A2B Ford Kit

The mObridge DA-G2.Entry A2B Ford kit contains the following items:

- / DA-G2 A2B Ford unit
- / CAN & Speaker wiring harness
- / Free software download for mObridge DSP application on our website www.mobridge.us (this is not provided in the package contents)

DA-G2.Standard A2B Ford & DA-G2.Pro A2B Ford Kits

The DA-G2.Standard A2B Ford and DA-G2.Pro A2B Ford kits include everything that is in the DA-G2.Entry A2B Ford Kit but adds an 8x RCA output cable for Analog Outputs.

MOBRIDGE
UNIT

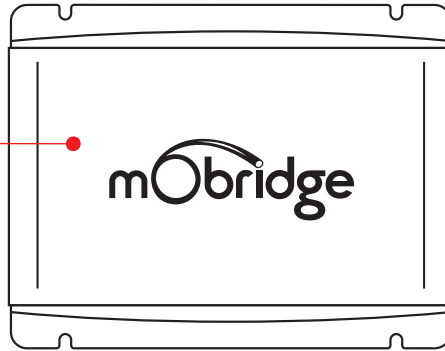

RCA CONNECTION
8 Channel RCA
connection (pro only)

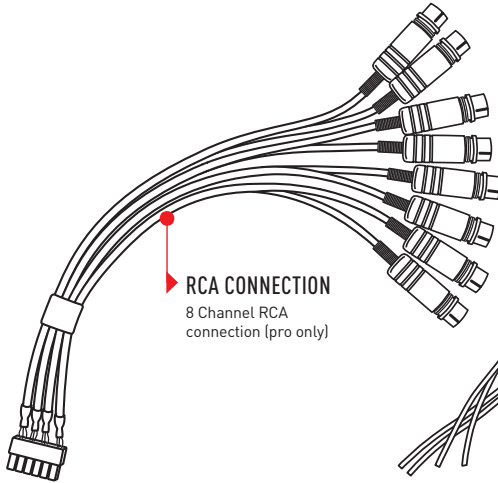

CAN & SPEAKER
WIRING HARNESS

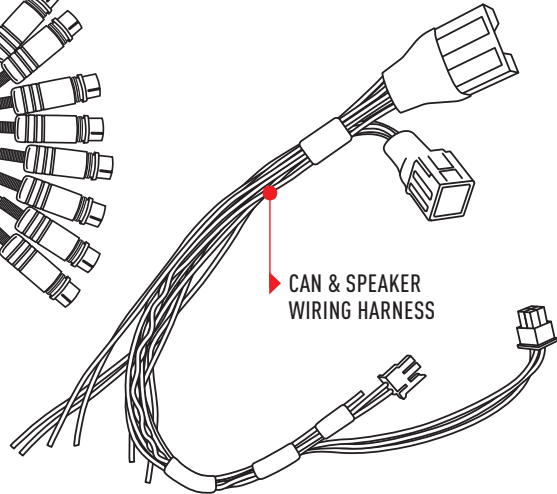

TECHNICAL SPECIFICATIONS

INPUT	
Digital Input	A ² B [®] Twisted Pair
OUTPUT	
Digital Outputs	TOSLINK (24bit 48kHz)
Frequency Response (Digital)	20Hz - 24KHz
Analog Outputs	10 Channels (RCA)
Output Voltage (Peak)	5.09
Output Voltage (RMS)	3.6V
Analog Output Type	Single-Ended
Signal-to-noise Ratio (Analog)	112dB
Frequency Response (Analog)	20Hz - 24KHz
THD+N @ -1dBFS	-107dbFS
Digital-Analog Converter	32bit 48kHz
Digital Signal Processor	32bit Blackfin Processor
POWER SUPPLY	
Current Consumption (Stand-by)	<3mA
Current Consumption (Operational)	300mA
Operational Voltage	8-22 Volts
Remote Turn on Output	Automatic
Remote Turn on Voltage	12V
Remote Turn on Current	500mA
OTHER	
Dimension	110mm x 80mm x 30mm
Weight	200g
Country of Origin	Australia

HARDWARE INSTALLATION

SYSTEM LAYOUT | DA-G2.ENTRY A2B FORD

FOR DA-G2 INSTALLATIONS, THE FACTORY AMPLIFIER
MUST BE REMOVED OR DISCONNECTED

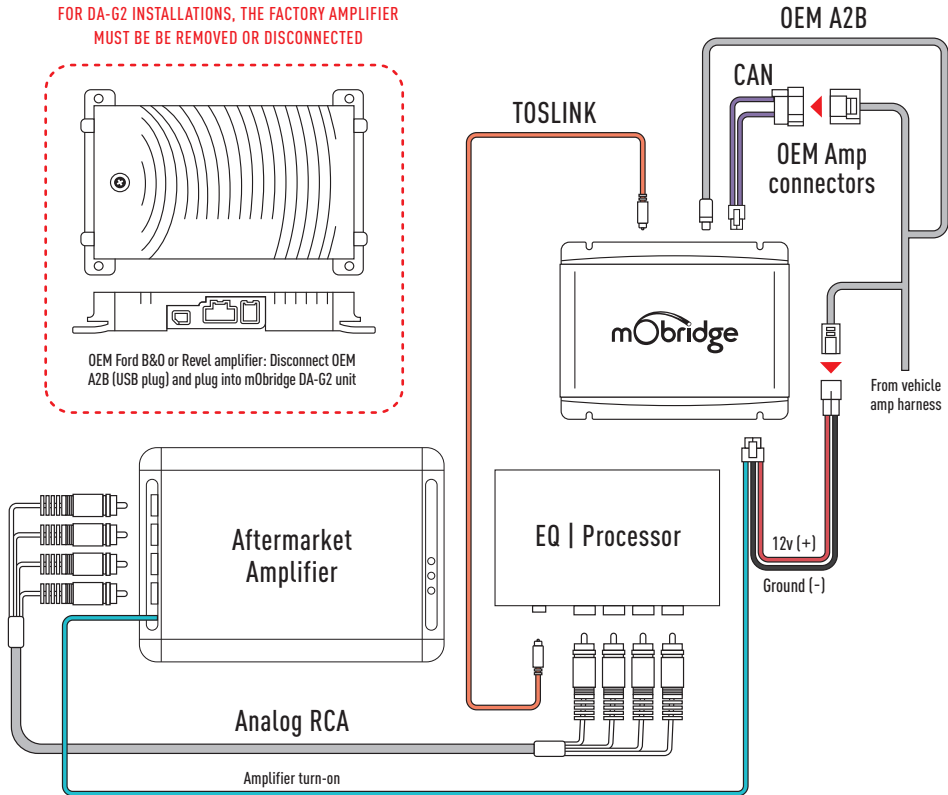
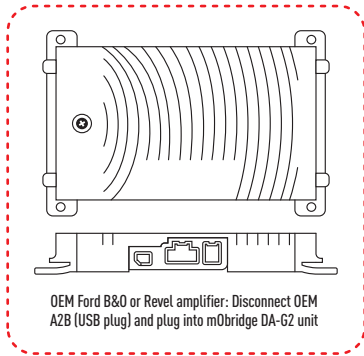

SYSTEM LAYOUT | DA-G2.STANDARD A2B FORD & DA-G2.PRO A2B FORD

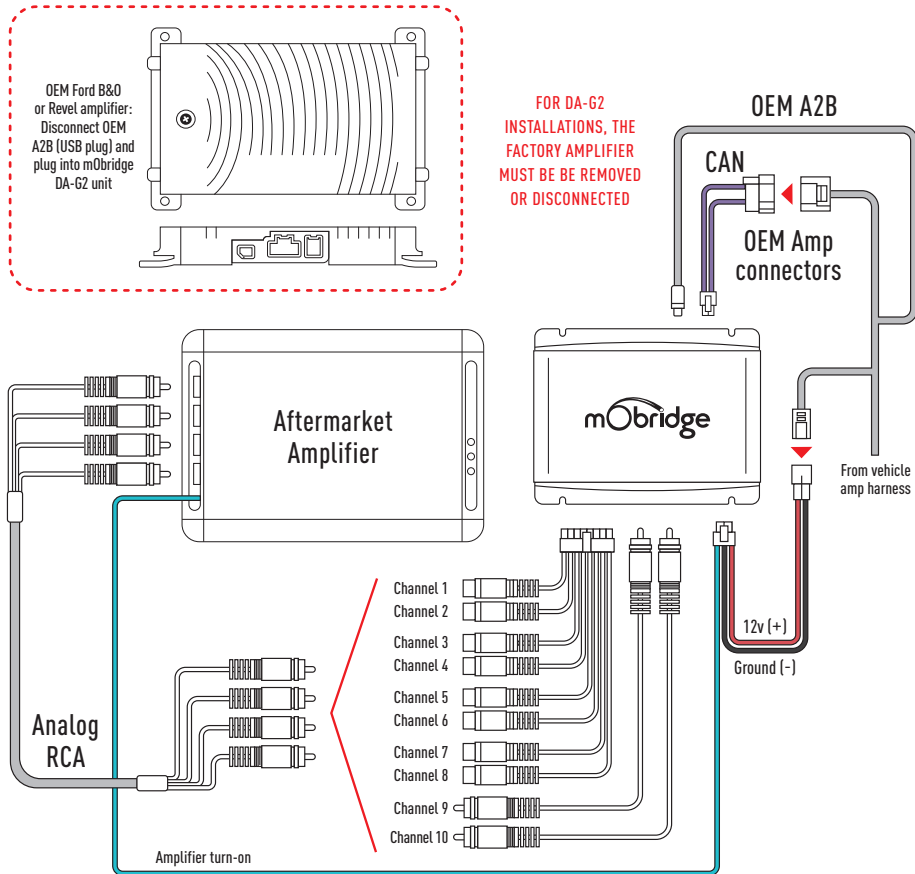

INSTALLATION GUIDE

WIRING HARNESS

- 01** For DA-G2 A2B installations, the factory amplifier must be removed and the DA-G2 unit can be installed in its place. After locating the factory amplifier, disconnect it entirely as it will no longer be used.
- 02** With the factory amplifier removed, connect the provided wiring harness to the previously removed OEM amplifier connectors (gray & black).
- 03** Connect the wiring harness to the POWER and CAN port on the DA-G2.
- 04** Connect the OEM A2B (USB) connector removed from the OEM amplifier to the A2B IN port on the DA-G2.
- 05** Connect the desired audio output(s) to the DA-G2: (Note: both Analog and Digital outputs can be used simultaneously)
 - a** If using analog RCAs for the signal to the amplifier, connect the provided RCA output harness to the ANALOG OUT port on the DA-G2.
 - b** If using the digital TOSLINK for the signal to the amplifier, connect a TOSLINK cable to the TOSLINK OUT port on the DA-G2.

REMOTE WAKEUP

The DA-G2 A2B Ford kits come with remote wake-up functionality. The remote wake-up wire (blue) is used to power on the amplifier with the vehicle's accessory power at the same time as the rest of the audio system. We recommend this be installed by a professional installation technician.

DIP SWITCHES

There are 6 dip switches on the DA-G2 A2B unit which are used to select which vehicle variant you are installing the unit in. For the default setting, ensure that all switches are in the down position as shown below.

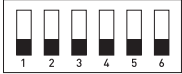
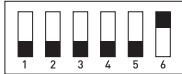
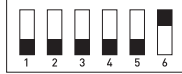
SWITCH SETTINGS	VEHICLE	MODEL YEAR	RADIO
	F-Series (F150, F250, F350, F450, F550)	2018-2021	SYNC3, SYNC4 with B&O or Revel amplifier
	Escape, Kuga, Focus, Endura, Everest, Ranger, Raptor, Explorer, Expedition, Mustang, Bronco, F-Series (F-150, F250, F350, F450, F550),	2021+	SYNC3, SYNC4 with B&O or Revel amplifier
	Volkswagen Amarok	2023+	B&O amplifier

Note: For exact model year compatibility please refer to the website compatibility list for this information, as some models of vehicles by year do differ.

FORD FACTORY PINOUT

To make the aftermarket amplifier installation process easier, the factory wiring and speaker harness plug (**FIG 02**) can be reused by wiring an aftermarket amplifier to the speaker harness. Please reference the table on the following page when connecting the aftermarket amplifier to the speaker harness.

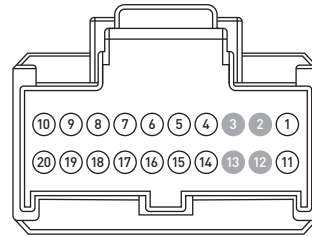

FIG 02 CAN & Speaker Wiring Harness

PIN NUMBER	DESCRIPTION	COLOUR
1	CAN High	Green/Blue
2	*Not Used	-
3	*Not Used	-
4	Centre Channel (-)	Gray/Yellow
5	Subwoofer 1 (-)	Gray
6	Front Right Door (-)	White/Orange
7	Front Left Door (-)	White/Brown
8	Rear Right Door (-)	Brown/Blue
9	Subwoofer 2 (-)	Yellow
10	Rear Left Door (-)	Brown/Yellow
11	CAN Low	White/Green
12	*Not Used	-
13	*Not Used	-
14	Centre Channel (+)	Green
15	Subwoofer 1 (+)	Green/Violet
16	Front Right Door (+)	White/Violet
17	Front Left Door (+)	White
18	Rear Right Door (+)	Brown/White
19	Subwoofer 2 (+)	Violet/Orange
20	Rear Left Door (+)	White/Green

POWER HARNESS

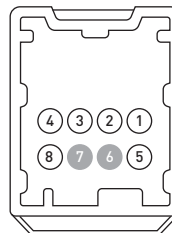

FIG 03 Power Harness

PIN NUMBER	DESCRIPTION	COLOUR
1	Ground	Black/Violet
2	CAN High (Lincoln only)	Green/Blue
3	CAN Low (Lincoln only)	White/Green
4	Constant 12v (+)	Brown/Red
5	Ground	Black/Violet
6	*Not Used	-
7	*Not Used	-
8	Constant 12v (+)	Brown/Red

LED STATUS

LED	LED STATUS	INDICATION
A (Leftmost)	Flashing	Audio Processing
B	Solid	A2B Link
C (Rightmost)	Solid	Master Sync

GRAPHICAL INTERFACE OPERATION

The mObridge DSP GUI (Graphical User Interface) can be downloaded from www.mobridge.us/mobridge-dsp-pc-application and can be used in both online and offline mode. However, in order to 'map the channels', you will need to be connected to the DA-G2 A2B with power connected. Offline mode allows you to configure Graphic EQ settings and store them for later fine-tuning in the car if desired. We recommend all tuning be done with a 'Live' system because this way you can hear all changes being made in real-time.

SOFTWARE UPDATE

The mObridge DA-G2 A2B series can be software updated via its USB connection and use of the mObridge DSP application that runs on Windows and macOS PC's.

Once the GUI has been installed, the latest DA-G2 A2B Ford software can be applied. The GUI can perform software updates either using the online

updater, or you can download the latest software for an offline update at www.mobridge.us/support

The mObridge DA-G2 A2B unit will need to be connected in the car and powered up for the unit to be updated. Once it has connected to the DSP GUI the user will be presented with the following screen (FIG 04).

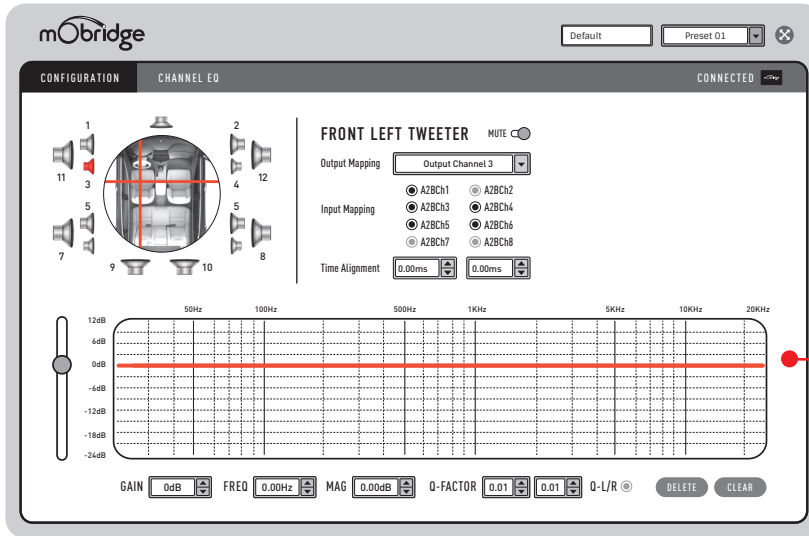

FIG 04 DA-G2 A2B is connected to the mObridge DSP GUI

Once the DA-G2 A2B is connected via the GUI we can just click on the 'Connected' button in the top right-hand corner and this will bring us to the update page as seen on the following page (FIG 05).

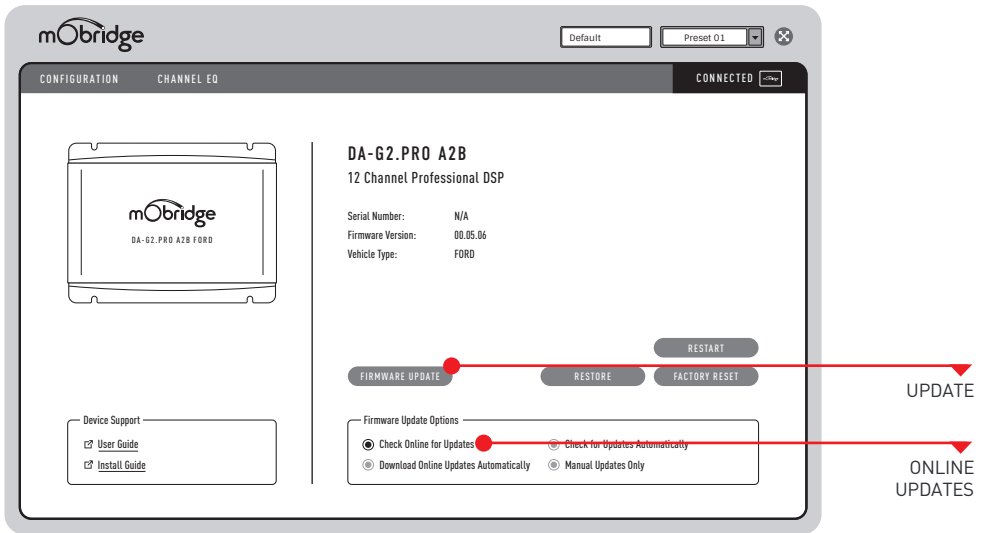

FIG 05 Update Page

If performing an online update, make sure the 'Check Online for Updates' option is ticked and then press the 'Firmware Update' button. This will automatically check for the latest software update for the connected device and begin the upgrade process.

If performing an offline update, make sure the 'Check Online for Updates' option is unticked and

then press the 'Firmware Update' button. This will open a window where you can select the new DA-G2 A2B Ford firmware file to update to and the update procedure will begin.

Once the update has completed, the DA-G2 A2B unit will reboot.

SPEAKER MAPPING

Once the DA-G2 A2B unit is connected to the mObridge DSP application, you will see the below screen (FIG 06).

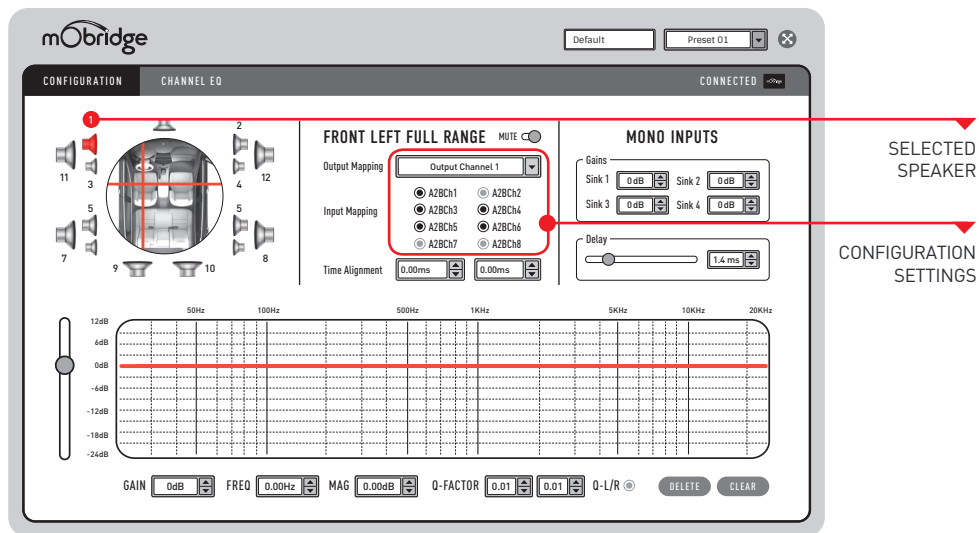

FIG 06 Configuration Page

This configuration screen will allow you to configure the channels for the correct mapping of your particular system.

First, select a speaker from the image of the vehicle in the top left corner, then select an output mapping

from the drop-down menu in the middle of the screen to select the channel output you have connected for that particular speaker. Repeat this for each speaker and its corresponding output channel.

When running a component speaker system with a passive crossover, only select one of the speakers in the cluster. It is not important which speaker is chosen, as this is only the mapping stage. Crossover settings will allow for correct settings for this type of speaker system.

Next, you will need to allocate the appropriate input mappings to each speaker. For each speaker, simply select the speaker image in the top left corner, and then click the appropriate 'Input Mapping' options for each speaker. If multiple input mappings are selected, these sources will be combined and summed.

SAVING SETUPS & PRESETS

The DA-G2 A2B will automatically save setups upon shutdown of the system. This needs to happen 'gracefully' meaning the car needs to go to sleep on its own, the user cannot just pull power from the unit as this will not work.

The DA-G2 A2B has four different presets and these can be tuned individually. The channel mapping will remain across all four presets. These can be selected with the drop-down menu in the top right corner as shown on the following page (FIG 07).

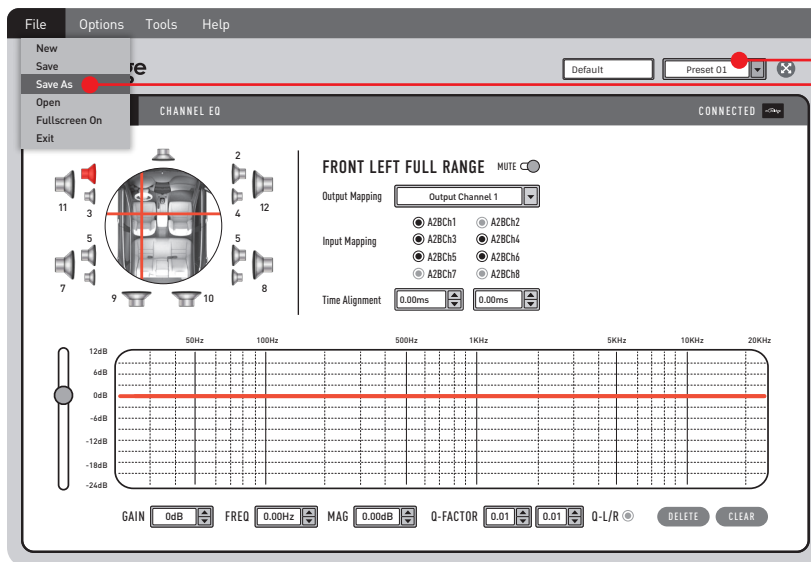

PRESET
NUMBER

SAVE
SETTINGS

FIG 07 Saving tuned settings

You can save a backup of all of your presets by simply clicking the 'File' button on the top menu bar and then 'Save As' as shown in the above screen. This will save a backup of your setup across all four presets and this file can be used to load in saved settings.

It is also possible to pull these presets up by using the “Adaptive volume” setting in the Ford head unit as shown on the screens below (FIG 08 & 09). This will allow you to switch presets as follows:

/ Off = Preset 1

/ Low = Preset 2

/ Medium = Preset 3

/ High = Preset 4

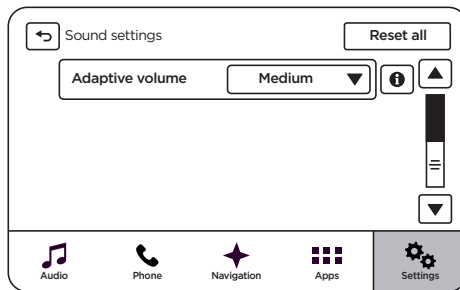

FIG 08 Presets settings

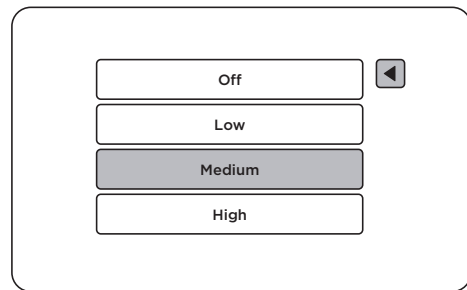

FIG 09 Adaptive volume settings

FCC INFORMATION (FOR US CUSTOMERS ONLY)

This equipment has been tested and found to comply with the limits for a Class B digital device, pursuant to Part 15 of the FCC Rules. These limits are designed to provide reasonable protection against harmful interference in a residential installation. This equipment generates, uses, and can radiate radio frequency energy and, if not installed and used in accordance with the instructions, may cause harmful interference to radio communications. However, there is no guarantee that interference will not occur in a particular installation. If this equipment does cause harmful interference to radio or television reception, which can be determined by turning the equipment off and on, the user is encouraged to try to correct the interface by one or more of the following measures:

- / Reorient or relocate the receiving antenna
Increase the separation between the equipment and receiver.

- / Connect the equipment into an outlet on a circuit different from that to which the receiver is connected.

- / Consult the dealer or an experienced radio/TV technician for help.

Warning: Any changes or modifications not expressly approved by mObridge, Inc. could void the user's authority to operate this equipment.

DISCLAIMERS

01 Dolby Digital, DTS and other proprietary digital formats are not supported by the DA series of products. These features require licensing from Dolby, DTS and other manufacturers to support these features.

02 Vehicle Coding

Some vehicles may require coding. mObridge endeavours to be aware of which vehicles and procedures are required for this by producing vehicle manufacturer installation notes. However, we will not be responsible should third party diagnostics tools be required, and nor will we be responsible for the costs involved in this coding or any monetary costs incurred either from third party diagnostics specialists/dealers or directly from consumers or installation specialists.

03 Vehicle features

Whilst mObridge endeavours to develop products that seamlessly integrate to the existing vehicle infrastructure, we will not be held legally responsible should some OEM vehicle features not operate as intended. Please be aware that mObridge does not have access to OEM vehicle data bases. When fitting a DA series product to the vehicle some features such as Bluetooth echo, volumes on specific sources such as Nav, Voice and Reverse Park distance may differ from the factory amplifier and this is due to end of line vehicle configuration at the manufacturer's factory.



MOBRIDGE.US

CONTACT US

PHONE +61 3 9465 5997 / INQUIRIES sales@mobridge.com.au



AUSTRALIAN
DESIGNED &
ENGINEERED